



## Adaptatone® Millennium Multiple Tone Signal

*PLC Compatible  
Voice Capability*

### 5531MV Series

#### FEATURES

- > Stand-alone, 27 tone capability - No additional tone modules needed
- > Output up to 110 dB @ 10 ft
- > PLC compatible
- > 20 sec. of field recorded Voice Messages
- > Suitable for Division 2 Locations
- > Captive Components

#### AGENCY APPROVALS

- > NEMA Type 3R
- > IP 44
- > UL 464 and 1604 Listed
- > UL Listed for indoor and outdoor applications in Class I, Division 2, Groups A, B, C & D; Class II, Division 2, Groups F & G; and Class III Hazardous Locations
- > cUL C22.2 No. 205 (24N5 model)

#### SPECIFICATIONS

- > Built-in cascading priority system
- > Speaker can be rotated and locked in any horizontal direction
- > 24V DC battery backup terminals

The Edwards 5531MV Adaptatone Millennium Voice unit is a heavy-duty industrial, tone-selectable, signaling device capable of producing volume-controlled, high-decibel tones and up to 20 seconds of field recorded voice messages. The Adaptatone Millennium Voice unit can be activated from field-wired, normally open contacts, or a 24VDC or 120VAC external voltage source such as an output of a PLC. Normally open contacts can be obtained from the Cat. No. 5538-4 and/or Cat. No. 5538-4R Adaptatone Signal Actuators. See page 4-49.

The unit uses a microprocessor circuit to create 27 distinctive tones and store 20 seconds of field recorded voice messages. Messages and tones may be selected by setting miniature dip switches within the unit. A total of four messages and tones programmed operate on a pyramid-type priority system. For more information on priority tone operation and a complete listing of all 27 tones, see page 4-55.

The 5531MV is designed for either 1/2" (13mm) conduit or surface mounting. See Adaptatone Signaling Installation, pages 4-56.

Designed for industrial applications including emergency warning, plant evacuation and security alarms, process monitoring, shift notification horns, paging and process control.



## TECHNICAL INFORMATION

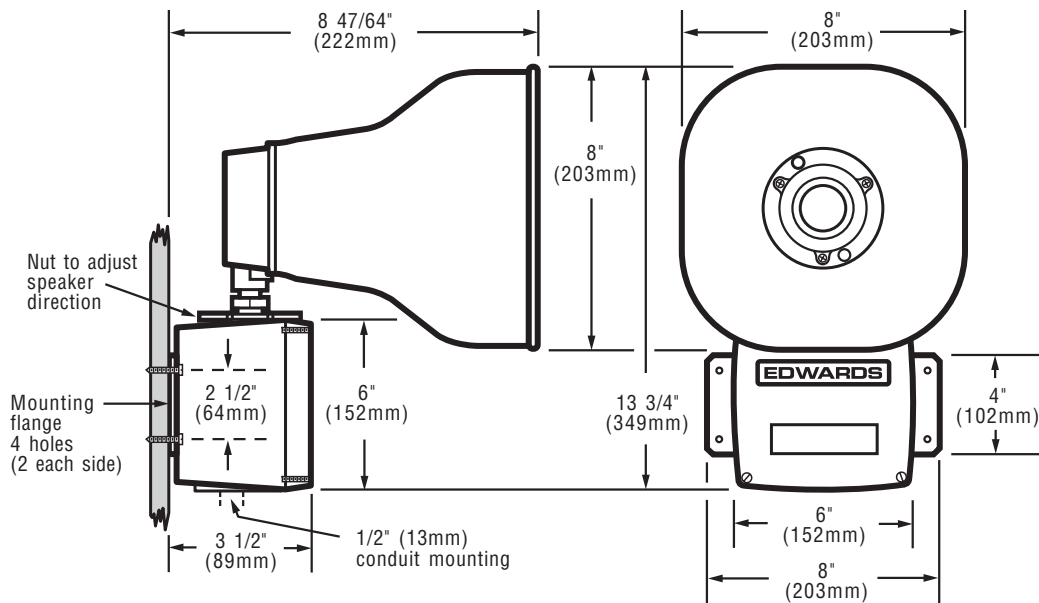

Cat. No.	Operating Voltage	Input Card Activation Voltage	Signal Off Standby Current (Amps)	Signal On Operating Current (Amps)
5531MV-24N5	120V AC 50/60 Hz	24VDC	0.10	0.23
5531MV-120N5	120V AC 50/60 Hz	120VAC	0.10	0.23

## SIGNAL INPUT LOAD CHARACTERISTICS\* (PLC output to meet following product input parameters)

Cat. No.	Operating voltage	Max. off state leakage current (mA)	Continuous on current (mA)	Surge (inrush/duration) Amps/milliseconds
5531MV-24N5	120V 50/60 hz	2	360	2.82/4
5531MV-120N5	120V 50/60 hz	5	380	2.82/4
24VDC Input Board	5V DC to 24V DC (each input)	2	6	—
120VAC Input Board	120VAC 50/60 Hz (each input)	5	13	—

\*This device is PLC compatible and may be operated by PLCs with output characteristics that match the input load requirements of this signal.