

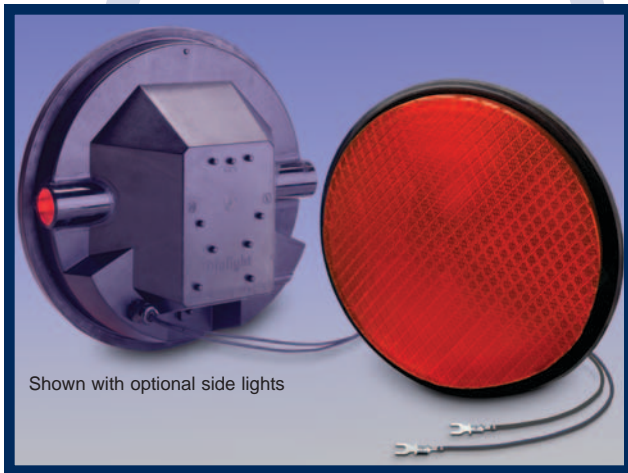

433 SERIES LED RAIL CROSSING SIGNAL MODULE



FEATURES / BENEFITS

- ▲ Proven high-flux LED traffic signal technology
- ▲ AC / DC operation from 5 to 16 volts
- ▲ Optional side light indicators reflect main beam signal to ensure safety
- ▲ Designed for retrofit into existing lamp housings with no beam alignment necessary
- ▲ Ring terminations easily attach to AREMA posts
- ▲ Red tinted, UV-stabilized, and hard-coated lens for extended life
- ▲ Better visibility and faster response time than incandescent
- ▲ Flicker resistant
- ▲ Reduced power consumption
- ▲ Years of maintenance-free operation

SPECIFICATIONS

Specification/Compliance:

AREMA - Meets or exceeds all applicable AREMA recommended design criteria*
Transport Canada - Meets or exceeds all applicable TC specifications*

The 433 series LED rail crossing signal was developed by Dialight for increased safety and reliability in rail applications. These lamps were designed utilizing Dialight's proven high-flux LED traffic signal technology for use on both existing and new crossing light applications. The faster on/off response time and brilliant monochromatic color make these LED lamps more noticeable than incandescent lamps. The modular lamps install easily without special tools and operate in both AC and DC applications. This light is unique from other LED crossing lights in several ways: (1) Diffused lens and uniform appearance are similar to incandescent, (2) the lamp maintains the specified light output down to 9 volts, but operates down as low as 5 volts, and (3) the side lights reflect light from the main beam via patented light pipe technology to ensure train engineers that the light aspect facing the street is actually flashing.

Dialight offers the state-of-the-art crossing signal with lower power, lower maintenance costs, safer turn-on response time, safety of side lights that monitor the main light beam, superior light performance, and superior quality and reliability!

* EMI compliance to FCC specifications only



Dialight Corporation

1501 Route 34 South • Farmingdale, NJ 07727 USA
Tel: (1) 732-919-3119 • Fax: (1) 732-751-5778 • www.dialight.com



a Roxboro Group Company

MDTRRCMX001_B

ELECTRICAL AND PHOTOMETRIC SPECIFICATIONS

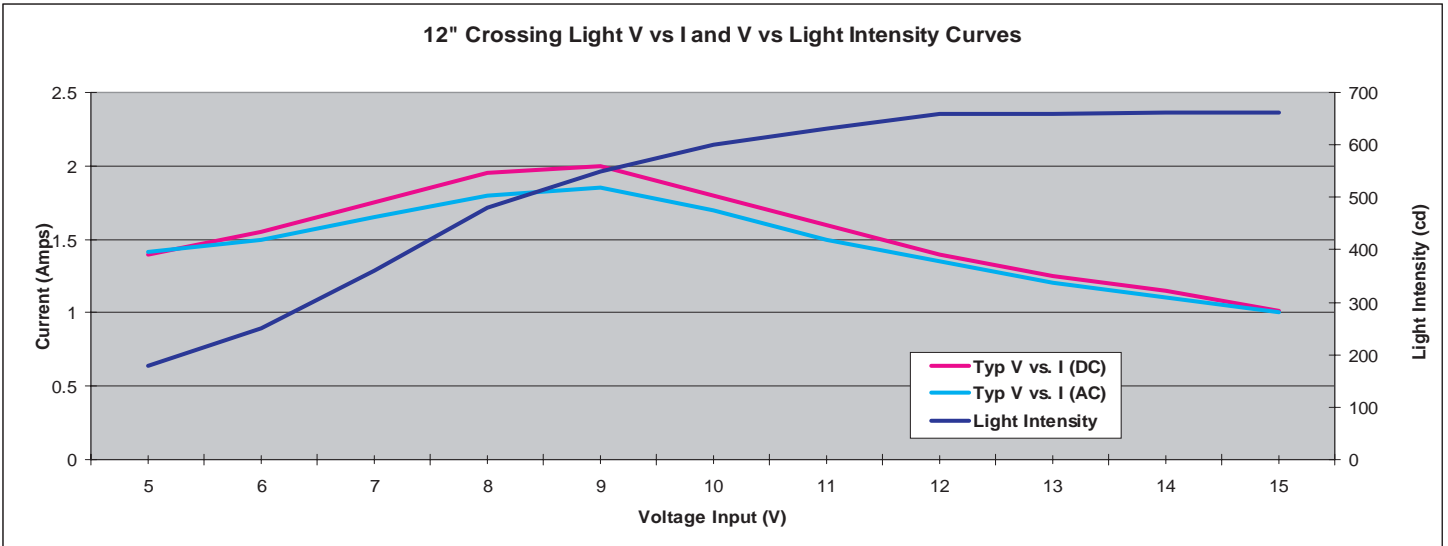

Typical Characteristics

- Operating Temperature-40°C to +70°C
- Operating Voltage5 to 16 volts AC/DC
- DC operating current @ 12 Volts1.5 Amps DC
- AC operating current @ 12 Volts1.5 Amps RMS
- Power Factor.....>98%
- Chromaticity $y \leq 0.330$ and $y \geq 0.998-x$

MECHANICAL DIMENSIONS

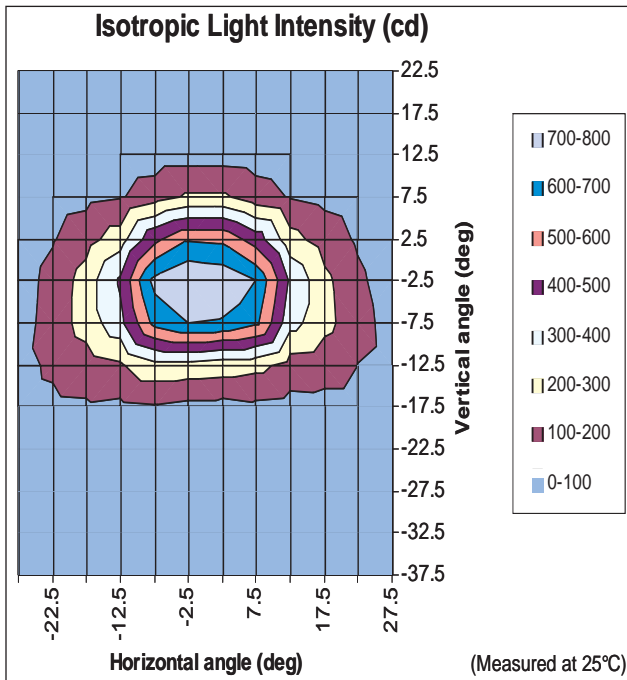
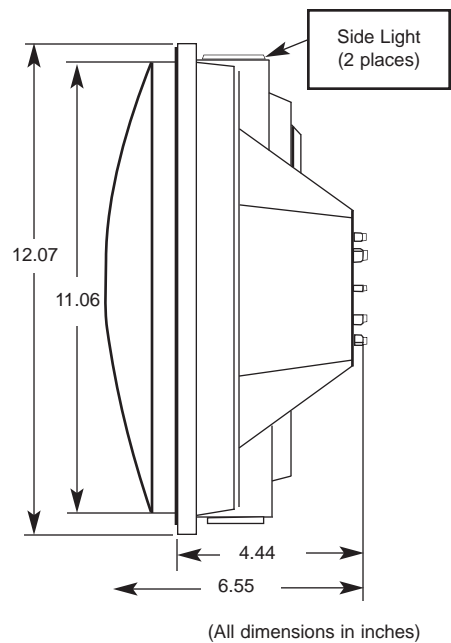

ORDERING INFORMATION

Standard
12 inch Flashing Signal

433-1R12-R111-1R00

12 inch Flashing Signal
with Side Lights

433-1R11-R111-1R00



Dialight Corporation
1501 Route 34 South • Farmingdale, NJ 07727 USA
Tel: (1) 732-919-3119 • Fax: (1) 732-751-5778 • www.dialight.com

