

# PRO III™ RCL/TDZ



## Runway Centerline Light or Touchdown Zone Light

**Compliances:** FAA AC 150/5345-46: L-850A; L-850B  
ICAO Annex 14: Fig. A2-5 and A2-7  
USN NAVAIR 51-50AAA-2  
Transport Canada Specification K 271: Fig B5 and B8  
UFC 3-535-01



**RCL / TDZ 8"**  
8" with 12" Ring

### Applications

The RCL/TDZ light does double duty as a runway centerline light and touchdown zone light. The RCL is a bidirectional light, typically clear/clear or clear/red, with two 48 W lamps. The TDZ is a clear unidirectional light, with a 48 W lamp. RCL /TDZ may be used for any category FAA, ICAO, or military runway.

### Features



- ETL Certified
- Low Profile, < .25" (6mm) – FAA Style 3
- Unique combination of high-strength aluminum optical assembly and ductile iron outer ring for Snow Plow Protection
- Low Power Consumption
- Few Parts to Stock
- Beam Orientation can be easily changed to left or right toe-in
- Easy to maintain – no sealant required for prism or feed-through assembly replacement
- Pressure test plug for seal integrity verification
- Long Lamp Life – Quartz Halogen, 48 W

### Ordering Information



**Fixture Type:**

- A = Runway centerline light
- B = Touchdown zone light

**Color Filters:**

- CC = Clear/Clear (L-850A)
- CR = Clear/Red (L-850A)
- C = Clear (L-850B)

**Fixture Diameter:**

- 12F = Optical assembly with 12" FAA support ring
- NSR = Optical assembly without support ring

**L-823 Plug Connection:**

- P1 = One plug
- P2 = Two plugs (L-850A only)

**Beam Orientation (L-850B only):**

- L = Left Toe-in
- R = Right Toe-in
- S = Straight

**Option:**

- G = External gasket between optical assembly and support ring\*

\* Optical assemblies with this option only fit support rings marked "G" on top surface.

## Outline Drawings

<b>Dimensions:</b>	inches (mm)
<b>Instruction Manual:</b>	9913
<b>Shipping Weight:</b>	23.0 lbs 10.4 kg
<b>Shipping Volume:</b>	0.7 cu ft 0.02 m <sup>3</sup>

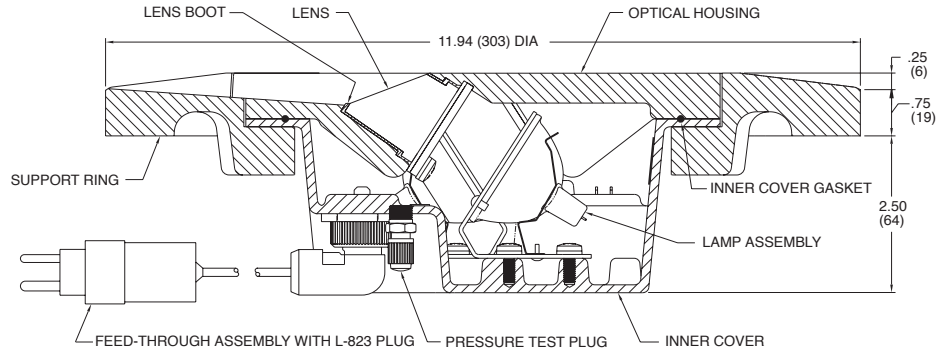

## Typical Photometric Data

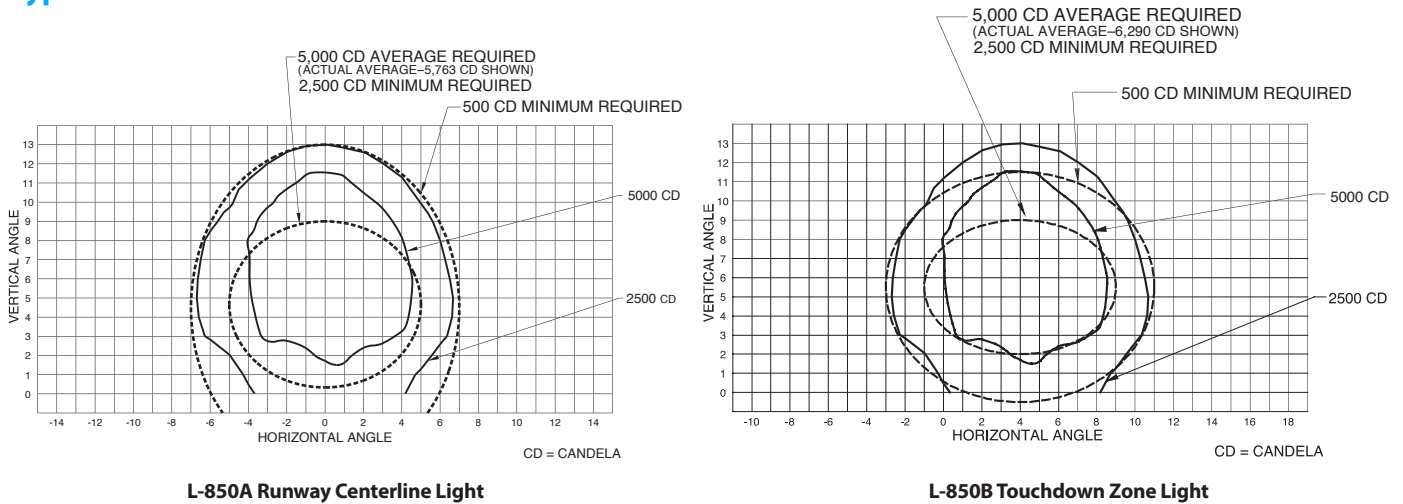

## Accessories

Catalog Number	Item Description	Catalog Number	Item Description
AC24242H200003	Base - L-868B, Class I, 24" Deep	823KP-D4-D4	Connector Kit - L-823, 8 AWG, .32" to .43" O.D.
33001	Isolation Transformer - 45 W, 6.6/6.6 A	10047-2154	Heat Shrink Kit - 1 Piece
33004	Isolation Transformer - 100 W, 6.6/6.6 A	10047-1425	Heat Shrink Kit - 2 Piece
33005	Isolation Transformer - 100 W, 20/6.6 A	21180	External Support Ring Gasket

## Renewal Parts

Part Number	Description	Part Number	Description
21116	Lamp - 48 W, 6.6 A	21121	Feed-through Assembly - 2 Lamp, 1 Connector
21126-C*	Lens Replacement Kit - Clear	21122	Feed-through Assembly - 1 Lamp, 1 Connector
21126-R**	Lens Replacement Kit - Red	10048-25	Gasket Lubricant - 5.3 oz Container
10035-62	Gasket - Bottom Cover	850X3-XX-NSR-XXX	Spare Optical Assembly

\* Includes 21102-C lens, 21103 lens boot, 21101 lens retaining gasket and gasket lubricant.

\*\* Includes 21102-R lens, 21103 lens boot, 21101 lens retaining gasket and gasket lubricant.

